(19)  **Canadian
Intellectual Property
Office**

An Agency of
Industry Canada

**Office de la Propriété
Intellectuelle
du Canada**

Un organisme
d'industrie Canada

(11) **CA 592439** (13) **A**

(40) **09.02.1960**

(12)

(21) Application number: **592439D**

(51) Int. Cl:

(22) Date of filing: ..

(71) Applicant: **CARLTON SHUTTLECOCKS LTD.**

(72) Inventor: **CARLTON WILLIAM C ().**

(54) **SPIGOTTED END SHUTTLECOCK**

(57) **Abstract:**

This First Page has been artificially created and is not part of the CIPO Official Publication

This invention relates to shuttlecocks, and particularly to the shuttlecock head.

In this specification the head of a shuttlecock is that part of the shuttlecock normally struck by the racket and indicated in the drawings herewith by the bracket A in Fig. 5 and the bracket A¹ in Fig. 6; the skirt of the shuttlecock is the flared portion indicated in Fig. 1 by the bracket B; the head is made up of two parts, the skirt end, which is moulded in one piece with the shuttlecock skirt and the cap which is a separate item made in one piece, incorporating an inner and an outer annular part and made of an elastic material such as rubber can be; the landing referred to hereafter is a surface on the skirt end which locates the inner face of the outer annular part of the cap, this landing is indicated as the item 9 on Figs. 1, 2 and 5, and as the item 9a on Figs. 6 & 7; each annular part referred to is a ring of rubber like material forming part of the cap, the rings are integral and concentric with each other and are indicated on Figs. 3 & 4 by the ring 8 and the ring 6.

A difficulty in shuttlecock manufacture is to fix the cap to the skirt end in such a way that the fixing will give reasonable service. A number of solutions have already been proposed to the problem but these have involved either relying entirely on an adhesive, or a re-entrant moulding or an extra fixing part other than adhesive.

An examination has been made of the cause of failure of adhesive fixing, and it has been found that the rubber-like cap expands on impact with the floor or racket, more than the skirt end, and this causes a gradual

breakdown of the adhesive joint. The object of this invention is to overcome this difficulty, and provide a shuttlecock cap which is very quickly assembled.

5 This invention is that, in a shuttlecock comprising a head and a flared skirt, the head being made up of a skirt end and a cap made of an elastic substance such as rubber can be and the skirt end incorporated at least a centre spigot and a landing, the head is character-
10 ised in that the cap incorporates at least two integral concentric annular parts, and the inner surface of the inner annular part tightly surrounds the spigot on the skirt end, and the inner surface of the outer annular part rests against the landing on the skirt end.

15 The invention is developed so that an inner annular groove on the skirt end mates snugly with the wall of the inner annular part of the cap.

The mating surfaces between the cap and the spigot on the skirt end may be secured additionally by adhesive if required.

20 The objects of the invention are:-

(a) To make the main joint between the skirt end and the cap in such a way that the 'working' which occurs in rubber-like substances when they are squeezed, is remote from the main securing surfaces between the skirt
25 end and the cap.

(b) To reduce fatigue at the top of the spigot on the skirt end by using the inner annular groove on the skirt end to reduce the sideways movement of the inner annular part of the cap.

30 A shuttlecock is constructed according to this invention by making a flared shuttlecock skirt, integral with a moulded skirt end, the skirt end being formed so that there is a spigot in the centre of the skirt end.

This spigot is of substantially smaller diameter than the outer diameter of the skirt end. An outer annular landing is provided on the skirt end, and this landing engages, on its outermost surface with the inner surface of the outer annular part of the cap, below described.

The cap is moulded of a rubber-like substance so that it incorporates at least two integral concentric annular parts, the inner one of which is considerably smaller in its inside diameter than the outside diameter of the spigot. When the inner annular part in the cap is forced over the spigot on the skirt end its inner surface fits tightly and may be still further secured by adhesive if required. The outer annular part in the cap is made so that when assembled, its inner surface rests against the landing on the cap end, and its inner surface is located by this landing.

When the shuttlecock is struck in play the outer annular part of the cap is subjected to distortion and working, whereas the inner annular part remains comparatively undisturbed except at the joint with the outer annular part.

By forming the skirt end so that an annular groove surrounds the spigot, the width of the groove being approximately the thickness of the wall of the inner annular part on the cap so that the two pieces made snugly, fatigue is reduced at the top of the spigot on the skirt end.

In order that this invention may be readily understood and carried into effect, a description follows referenced to the accompanying drawings in which:-

Fig. 1 Is a side elevation of a typical flared shuttlecock skirt with a skirt end.

Fig. 2 Is a partial plan view of the above in the direction of the arrow X.

Fig. 3 Is a perspective view of a typical cap.

Fig. 4 Is a section through the cap shown in Fig. 3.

Fig. 5 Is a section showing the assembly of the cap shown in Fig. 3 to the skirt end in Fig. 1.

5 Fig. 6 Is a side elevation, partly in section of an alternative embodiment of the invention.

Fig. 7 Is a partial plan view of the embodiment shown in Fig. 6. in the direction of the arrow Y.

Referring now to Figs. 1, 2, 3, 4 and 5, a
10 flared shuttlecock skirt 1 is moulded integrally with a skirt end 2 which is designed to mate with a cap 3 moulded from an elastic rubber. The skirt end 2 is provided with a spigot 4 which is of a diameter which makes it a tight
15 fit against the inner surface of the inner annular part 5 of the cap 3. The wall 6 of the inner annular part 5 of the cap 3 is adapted to mate snugly with the wall of the inner annular groove 7 in the skirt end 2 as shown in Fig. 5.

The wall of the outer annular part 8 is adapted
20 to rest snugly with its inner surface against the landing 9 in the skirt end 2, as shown assembled in Fig. 5.

Referring now to Figs 6 and 7, an alternative construction of an embodiment of the invention is shown, in this instance the inner annular groove 7a is much wider
25 than the thickness of the wall 6a of the cap 3a, no support is therefore given to the cap by the outer wall of the inner annular groove 7a.

In Figs. 6 and 7, 1a is the flared skirt, 2a is the skirt end, 4a is the spigot, 9a is the landing, and
30 cap 3a similar to the cap 3 is provided to nest as shown.

The embodiments of the invention in which an exclusive property or privilege is claimed are defined as follows:

1. A shuttlecock comprising a head and a flared skirt, the head being made up of a skirt end and a cap, the skirt end incorporating at least a centre spigot and a landing; and the head being characterised in that the cap incorporates at least two integral concentric annular parts, and the inner surface of the inner annular part tightly surrounds the centre spigot on the skirt end, and the inner surface of the outer annular part rests against the landing on the skirt end.

2. A shuttlecock as in Claim 1 and characterised in that an inner annular groove on the skirt end mates snugly with the wall of the inner annular part of the cap.

Alex. E. MacRae & Co.
56 Sparks Street,
Ottawa, Ont. Canada.
Patent Agents for Applicant.

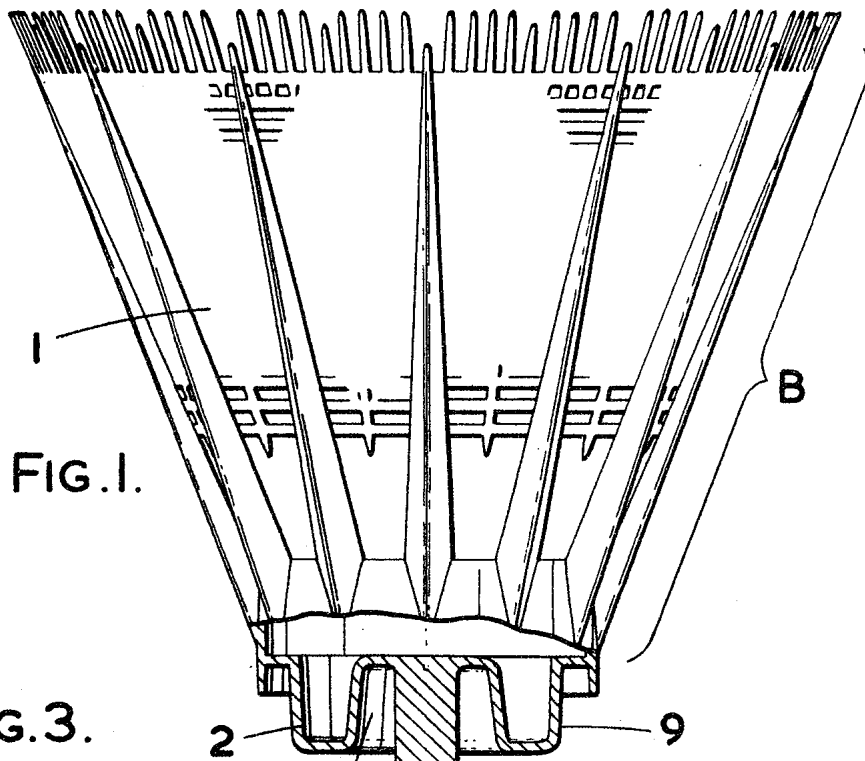

FIG. 1.

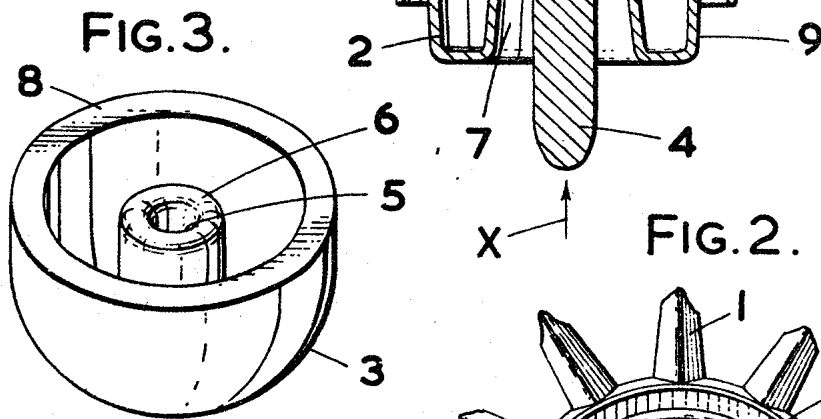

FIG. 2.

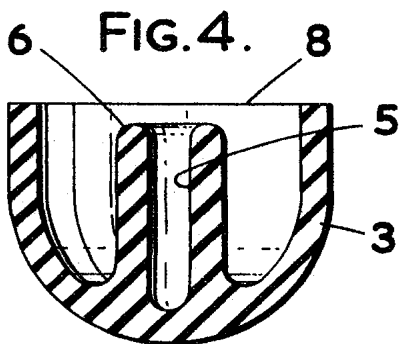

FIG. 3.

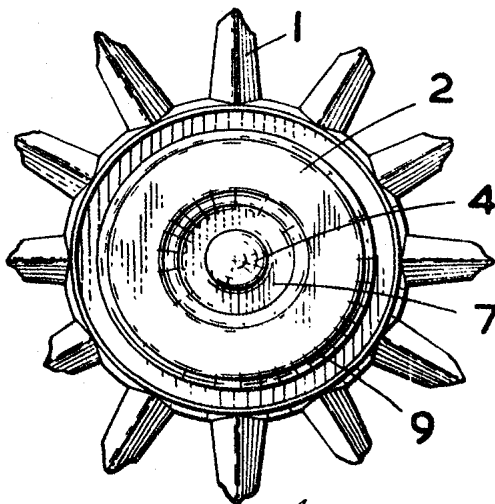

FIG. 4.

Inventor
 William Charles Carlton
 Patent Agents
 Messrs. E. Maestri & Co.

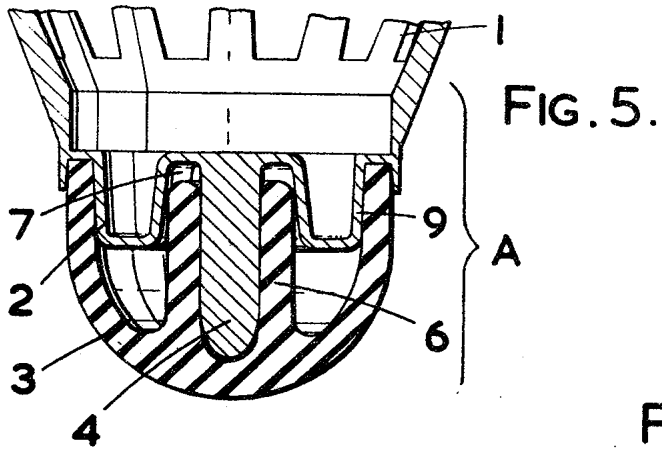

FIG. 6.

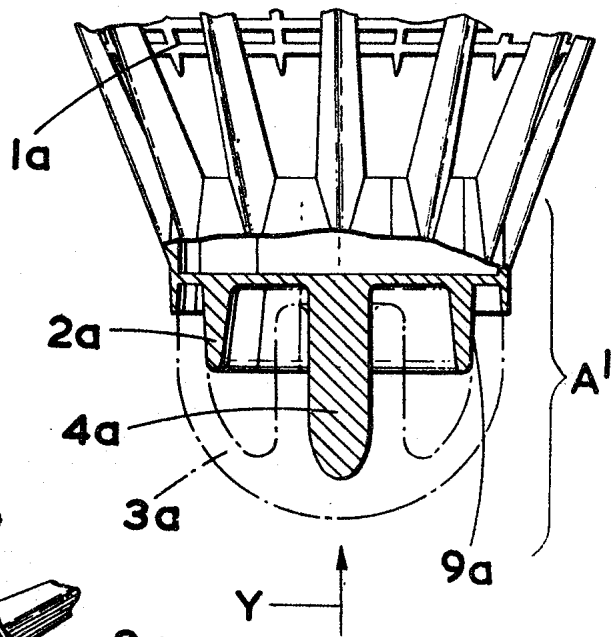
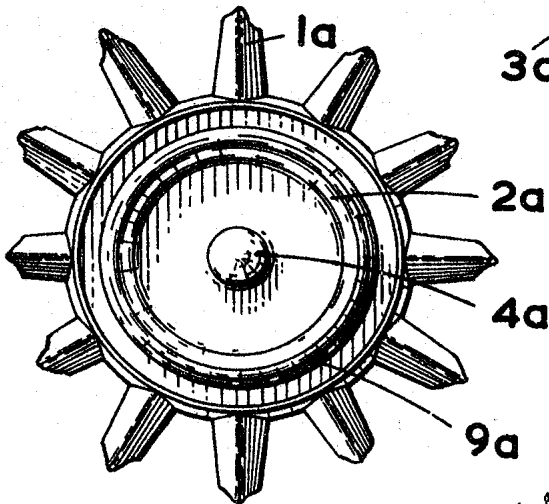

FIG. 7.



Inventor
 William Charles Carlton
Patent Agents
 Alex. C. Mackay & Co.