

RESERVE COPY.
PATENT SPECIFICATION

908,684

DRAWINGS ATTACHED.

Inventor:—WILLIAM CHARLES CARLTON.



Date of filing Complete Specification : Jan. 30, 1959.

Application Date : Feb. 3, 1958. No. 3431/58.

Complete Specification Published : Oct. 24, 1962.

Index at Acceptance:—Class 132(3), S28.

International Classification:—A63h.

COMPLETE SPECIFICATION.

An Improved Shuttlecock and Skirt Structure Therefor.

We, THE CARLTON TYRE SAVING COMPANY LIMITED, of Parkstone Works, Wingle-
tve ~~London~~ Kingdom Patent Specifications Nos 670 147
CORRECTION OF CLERICAL ERROR

SPECIFICATION NO. 908,684

The following correction is in accordance with the Decision of the
Superintending Examiner, acting for the Comptroller-General, dated the 13th day of
April, 1964

Page 2, line 82, for "2.2" read "5.0"

Attention is also directed to the following printer's errors:—

Page 1, line 77, for "coses" read "cases"

Page 2, line 91, for "caock" read "cock"

Page 2, line 93, for "binde" read "dined"

Page 4, line 72, for "fo" read "of"

Page 5, line 53, for "spon" read "spin"

Page 5, line 70, for "nuhber" read "number"

Page 5, line 99, for "les" read "less"

Page 5, line 117, for "for" read "from"

THE PATENT OFFICE,

1st July, 1964

35 material called the "Striking Cap". Such
shuttlecocks herein called "Feather Shuttle-
cocks" are relatively fragile and expensive
and efforts have been made for many years
to utilise substitute materials in place of
natural feathers.

40 In about 1950 moulded plastics shuttle-
cocks were developed successfully, such for

D 6444/1(5)/P.109 200 6/64 PL

angling can produce a spinning effect about 75
the main axis of the shuttlecock. In some
coses, curved shafted feathers giving a spiral
effect have also been used, particularly in
the cheaper types of feather shuttlecock.

The present invention is directed particu- 80
larly to shuttlecocks in which the cone-
shaped structure, corresponding to the

PATENT SPECIFICATION

908,684

DRAWINGS ATTACHED.

Inventor:—WILLIAM CHARLES CARLTON.



Date of filing Complete Specification : Jan. 30, 1959.

Application Date : Feb. 3, 1958. No. 3431/58.

Complete Specification Published : Oct. 24, 1962.

Index at Acceptance :—Class 132(3), S28.

International Classification :—A63h.

COMPLETE SPECIFICATION.

An Improved Shuttlecock and Skirt Structure Therefor.

We, THE CARLTON TYRE SAVING COMPANY LIMITED, of Parkstone Works, Wingle-
tye Lane, Hornchurch, Essex, a British
Company, do hereby declare the invention,
5 for which we pray that a patent may be
granted to us, and the method by which
it is to be performed, to be particularly de-
scribed in and by the following statement:—

10 This invention relates to shuttlecocks hav-
ing skirts made of artificial material. The
shuttlecock which has been developed for
serious play in the game of Badminton over
many years, is a games missile having very
distinctive flight characteristics and a right
15 regular conoidal shape.

It is convenient in this Specification, to
give certain definitions of some terms which
will be used.

20 "Badminton Shuttlecock" will denote a
shuttlecock which behaves in a manner to
which the Badminton player has become
accustomed.

25 "Shuttlecock" will include a games missile
having the flight characteristics and general
profile of a shuttlecock, which is suitable for
"knock about" play, but which does not
necessarily conform with the rigid require-
ments for high class Badminton play.

30 Over many years shuttlecocks and in par-
ticular Badminton shuttlecocks developed
into a convention structure composed mainly
of feathers set into a substantially hemi-
spherical member of cork or similar ma-
terial called the "Striking Cap". Such
35 shuttlecocks herein called "Feather Shuttle-
cocks" are relatively fragile and expensive
and efforts have been made for many years
to utilise substitute materials in place of
natural feathers.

40 In about 1950 moulded plastics shuttle-
cocks were developed successfully, such for

example as are described in United
Kingdom Patent Specifications Nos. 670,147
and 686,403.

45 Where in this Specification it is required
to draw a distinction between a feather
shuttlecock and one made by moulding the
skirt of artificial material, the latter will be
referred to as a "Moulded Shuttlecock", or
50 by reference to the material of which it is
principally composed, e.g. a "Plastic
Shuttlecock".

55 The conventional feather shuttlecock com-
prises an assembly of suitably trimmed
feathers arranged in the form of a flared
cone, at the narrow end of which the quills
of the feathers are inset into a striking cap
of substantially hemispherical shape usually
made of cork. The quills of the feathers
60 are shaven clean from the stem for some
distance away from the striking cap. At
the outer wide end of the cone, the flight
portion of each feather is trimmed into a
substantially oval shape and the feathers are
65 mounted with the flight portions in over-
lapping relationship. This portion of the
feathered shuttlecock is herein termed the
"Vane Area". One or two circumferential
rows of binding such as thread are usually
70 employed between the cap and the vane
area. The overlapping of the flight portions
of the feathers is usually obtained by angling
the vexillum so that it intersects the surface
of the cone of the shuttlecock and this
75 angling can produce a spinning effect about
the main axis of the shuttlecock. In some
cases, curved shafted feathers giving a spiral
effect have also been used, particularly in
the cheaper types of feather shuttlecock.

80 The present invention is directed particu-
larly to shuttlecocks in which the cone-
shaped structure, corresponding to the

assembly of feathers in a feather shuttlecock and herein termed the "Skirt", is produced by a moulding operation of a suitable substance.

5 To support and retain the shape of the skirt of a moulded shuttlecock, it is desirable to provide stiffening members similar in function and general location to the quill portions of a feather shuttlecock. These members are herein called "Stems". In the case of a plastics skirt moulded in one piece, the parts of these stems which converge at the narrow end of the cone, herein called the "Root Ends", finally merge together to form a continuous ring herein called the "End Ring".

10 The present invention is concerned with improvements in shuttlecocks and Badminton Shuttlecocks, of the type comprising a moulded skirt divisible into two zones, namely an outer zone, which is herein called the "Lower Skirt", located remote from the cap and constituting the vane area, and an inner zone which is herein called the "Upper Skirt" located between the lower skirt and the cap. The lower skirt occupies not less than 30% and not more than 70% of the total length of the skirt, and the upper skirt is constituted by stems having large air spaces between them, not less than seven and not more than twenty five stems being provided. By "large air spaces" is meant air spaces which permit a sufficiently free passage of air from the outside to the inside of the shuttlecock, past the stems, to enable that air flow to act on the surfaces of the stems in the upper skirt, for the purpose of controlling the motion of the shuttlecock. Moreover, in the type of shuttlecock with which this Specification is concerned, no part of any stem in the upper skirt extends outside the surface of the cone defined by the outer surface of the stems in the area of the lower skirt: this distinguishes shuttlecocks of the present invention from shuttlecocks which have fins or vanes fixed outside of the above surface.

A problem with shuttlecocks having moulded skirts is that in certain conditions of play, the lower skirt tends to fold back upon itself due to sudden reversal of loading when the shuttlecock is struck hard by the racket.

55 It has been suggested, as a partial cure for folding back, to curve the stems of an artificial shuttlecock in the skirt, so that they are spiral in formation, but we have not found this to be an entirely satisfactory solution to this problem. The present invention aims at prevention rather than cure, and provides a different and more effective solution.

60 A further problem in the manufacture of high quality shuttlecocks, such as Badminton shuttlecocks, from artificial material, is to

combine the necessary lightness of weight in the lower skirt with the general stiffness which is necessary for the skirt as a whole, and at the same time to provide a means for making the shuttlecock spin at a relatively slow and steady speed and for retarding spin if the shuttlecock is spinning too quickly, and certain embodiments of the present invention are intended to provide a solution to this problem.

70 There is no difficulty in obtaining stiffness and spinning qualities by structures which increase the over-all weight of a moulded shuttlecock, but this must be avoided at all costs since it is necessary to approximate to the weight of a good quality feather shuttlecock, which is of the order of 2.2 grams. This means that every opportunity must be taken to reduce the amount of material employed in a moulded shuttlecock. The quill of a feather obtains its lightness and stiffness from its cellular construction.

80 As explained in our prior Specification No. 670,147, when using artificial materials in the manufacture of a moulded shuttlecock, it is necessary to provide a free passage of air through the upper skirt combine with lightness and considerable drag in the lower skirt.

95 Our prior Specification No. 686,403 describes a moulding technique which enables the skirt of a moulded shuttlecock to be formed with extreme lightness, and yet with adequate strength due to the presence of the stems and of the ribs extending between the stems in the vane area. Using that moulding technique and subsequent developments of it, it is theoretically possible to provide a moulded shuttlecock in which some or even all of the small holes between the stems and the ribs in the lower skirt, are filled up by a very thin foil or web of moulded plastics impervious to the passage of air. Such a shuttlecock would have a satisfactory trajectory.

100 It would of course be easy to mould an impervious lower skirt by other methods by permitting a fractional increase in average thickness (and hence in total weight) of the various components of the lower skirt, but so strict are the weight limitations for high quality shuttlecocks, that such a weight increase could adversely affect the quality of the shuttlecock.

115 To mould a skirt with a sufficiently thin foil between the stems and ribs in the lower skirt and within the weight limits prescribed for a satisfactory Badminton Shuttlecock, involves such technical precision that it is not, at present, an economic construction for the mass production of shuttlecocks. Therefore, when mass producing moulded shuttlecocks and Badminton shuttlecocks, we prefer to employ a construction in which the lower skirt is perforate, with very small

70

75

80

85

90

95

100

105

110

115

120

125

130

holes between the stems and ribs, e.g. such as is illustrated in prior Specifications Nos. 686,403 and 887,172.

When such a shuttlecock is in flight, some of the air passes over the striking cap and along the outside surface of the whole skirt; the remainder of the air passes inwardly between the stems in the upper skirt and out through the inside of the skirt, a part travelling along the inside of the lower skirt structure, but some of it converging towards the centre of the cone formed by the skirt. Relatively little air flow takes place through the small holes in the lower skirt, by comparison with that which takes place through the larger holes between the stems in the upper skirt. It will thus be seen that the air flow between the stems in the upper skirt can, under appropriate conditions, be caused to act upon the side surfaces of the stems, and control the motion of the shuttlecock in flight.

By the expression "Side Surfaces" of the stems is meant those surfaces of the stems which are opposed or substantially opposed to each other between adjacent stems, as distinct from the outer surface of the stems which is that surface substantially coincident with the outer surface of the shuttlecock skirt.

According to the present invention there is provided a one piece moulded flared skirt structure for shuttlecocks of the type specified having an end ring from which stems supporting the vane area extend outwardly, characterised in that the average depth of the stems in the region of the upper skirt is at least twice and not more than eight times the average widths of the said stems in the same region.

References to the "depth" of the "cross sectional depth" of a stem and to "deep" or "shallow" stems, all refer to that dimension of the stem which traverses the circumferential plane of the shuttlecock in a generally radial direction or at a slight inclination to a radial direction. References to the "width" or the "cross-sectional width" of a stem, or to "wide" or "narrow" stems, all refer to that dimension of the stem which traverses the radial plane of the shuttlecock in a generally circumferential direction or at a slight inclination to a circumferential direction.

The deep stems are preferably tapered regularly in cross sectional depth from a maximum at their root end, to a minimum at their outer end, i.e. at or close to the outer fringe of the lower skirt. It has been found that this feature of depth combined with taper is effective in preventing the shuttlecock from folding back.

The centre lines along the outside surfaces of the stems are straight and lie in

the surface of the frustum of a right circular cone.

In one arrangement, the projection of the centre line along the outside surface of each stem passes through a common point on the main axis of the shuttlecock but in some cases an alternative arrangement may be adopted in which the stems are "laid back", that is to say that the projection of the centre line along the outside surfaces of each stem, does not pass through any point on the main axis of the shuttlecock, but passes through a circle generated from that main axis in a plane perpendicular to that axis.

Considering the shuttlecock (and hence the stems) in plan and cross section, the centre line through the depth of the deep stems may be coincident with a radius generated from the main axis of the shuttlecock in a plan normal to that axis. Alternatively the stems may be "angled", that is to say that the centre line through their depth may be inclined slightly to a radial line, passing from the centre of the outside of the stem to the main axis of the shuttlecock in which case said centre line will be tangential to a circle concentric with the shuttlecock, and at least the side surfaces of the angled stems will also be inclined with respect to the radial line.

It is important for accuracy of trajectory that the deep stems should be regularly spaced around the perimeter of the shuttlecock.

It has already been stated that certain embodiments of this invention aim to provide means for enabling the shuttlecock to spin slowly in flight, or to retard any tendency for it to spin too fast. The depth of the stems in the upper skirt, and the fact that their side surfaces are directly exposed to the action of the air flowing through the upper skirt, enables these stems to be used to resist any tendency to excessive spin or, in certain cases, as described hereafter, to impart spin where no spin has been imparted by the racket. Moreover, our construction achieves this spin control with a minimum of weight increase in the skirt, and at the same time with only a very small loss of stiffness in the skirt structure.

In prior Specification No. 724,673, an injection moulded shuttlecock has a single piece body with a cupola-shaped front portion (or striking cap) and a tail portion (or skirt) substantially forming a truncated hollow cone, the wall of said cone being provided with slots and forming oblique flight stabilising surfaces, causing the shuttlecock to rotate during its flight, these stabilising surfaces merging into one another in step-like order by means of radial wall portions extending substantially helically over a part of the length of said cone. The stepped portions are in the lower skirt of

that shuttlecock and are spiral. They appear to merge at or about the junction with the upper skirt which is provided with large slots. The portions between the slots which, to some degree, correspond with the stems of the present invention, do not exert a substantial stiffening effect. They appear from the drawing to be T-shaped in cross-section in the upper skirt, and the width across the top of the T is greater than the depth. Moreover, the side surfaces of these portions, if they can be regarded as stems, are not, in this construction, directly exposed to the action of air flowing through the upper skirt, due to the presence of that part of the wall of the cone between the slots, which constitutes the cross bar of the above mentioned T-section.

In the case where it is desired to make a shuttlecock according to the present invention with a tendency to spin, the construction may be used in which the centre line through the depth of the deep stems lies in the diametrical line of the shuttlecock, and the stems are straight and laid back. This laying back will tend to make the shuttlecock spin.

Spinning may also be induced by angling the centre line through the deep stems, or the line along the side surfaces of such stems, and the features of laying back and angling the stems, may of course be combined, since they both tend to promote spin.

In order that the invention may be clearly understood and readily carried into effect several embodiments of the invention are now described with reference to the accompanying drawings in which:—

Fig. 1 is a side elevation of a typical shuttlecock made in accordance with this invention in which the stems are neither angled nor laid back.

Fig. 2 is a plan view of the shuttlecock of Fig. 1, looking into the cone.

Fig. 3 is a section at III—III of Fig. 1.

Fig. 4 is a side elevation of a development of the invention in which the stems are angled slightly.

Fig. 5 is a plan view of the shuttlecock of Fig. 4 looking into the cone.

Fig. 6 is a section at VI—VI of Fig. 4.

Fig. 7 is a side elevation of a further development of the invention, in which the stems are angled more than in Fig. 4.

Fig. 8 is a plan view of the shuttlecock of Fig. 7 looking into the cone.

Fig. 9 is a section at IX—IX.

Fig. 10 is a side elevation of a further development of the invention in which the stems are both angled and laid back.

Fig. 11 is a plan view of the shuttlecock of Fig. 10 looking into the cone.

Fig. 12 is a section at XII—XII.

In the example shown in Figs. 1, 2 and 3, the shuttlecock skirt comprises a flared

lower skirt or vane area L carried by stems G which stems converge towards their root ends, which are attached to a tube M. The tube M merges with or constitutes part of the end ring (not shown) which extends into the striking cap A, which is made of cork covered with kid, or of other suitable material. A band B is provided in conventional manner to secure the kid cover to the cap.

The bracket C indicates a typical length of lower skirt, in the order of 60% of the total skirt length, while the bracket E indicates a typical length of upper skirt, being the remaining 40% of the total.

The bracket D indicates the maximum length for the lower skirt, namely 70% of the total skirt length, the bracket F indicating the minimum upper skirt length, being the remaining 30% of the total.

The consequence of reducing the length of the upper skirt is to restrict the quantity of air which can pass through the large air holes H in the upper skirt. Obviously this is a matter of degree. As the invention depends, for proper functioning of the shuttlecock, upon the effect of the air on the side surfaces of the stems G in the upper skirt, we have found that the minimum of 30% below which the air flow will begin to seriously lose its effect through restriction.

Between seven and twenty five (in this instance sixteen) stems G are provided and whilst such stems do run into the lower skirt, this invention is concerned primarily with the depth and the angle of these stems in the upper skirt. In the example shown it will be noticed that the stems taper and vary in depth and width along their length, and in our definition of "depth" and "width" mention is made of the "average depth" and "average width" of the stems, i.e. the mean depth and width when due allowance has been made for the taper. Unless the average depth of the stem in the region of the upper skirt is at least twice the average width in the same region the result will be unsatisfactory because insufficient area of the side surfaces of the stems will be directly exposed to the air flowing through the large holes H, and if the average depth is greater than eight times the average width then the lower skirt of the shuttlecock will become too heavy. A pair of arrows J in Figure 3 indicates what is meant by the depth of the stem and a pair of arrows K indicates what is meant by its width. Large air spaces H have been left between the stems with the object of allowing air to flow freely from the outside to the inside of the skirt. It would be permissible to have widely spaced rings P as shown in one panel, and these stems may extend right round the shuttlecock, providing that the

space between the rings is sufficient to allow an effective passage of air. It will be understood that the rings have only been shown in one panel for the sake of clarity.

5 In the example of Figs. 1 to 3 a number of small air spaces Q are provided in the lower skirt but this feature is not concerned with this invention. Air spaces as small as those indicated at Q do not allow a sufficiently free passage of air for the air flow to exert any appreciable effect upon the side surfaces of the stems G where these extend into the lower skirt.

10 By connecting the root ends of the stems G to the tube M strength is increased. Since the tube M extends substantially parallel with the axis of the shuttlecock and in the same general direction as the air flow, it does not materially restrict the air flow through the stems in the upper skirt.

20 The diameter NN is a typical diameter and in this example the centre line through the depth of each stem is in line with this diameter. In other words, the stems in this example are neither "angled" nor "laid back".

30 In this embodiment, as in those illustrated in Figs. 4—6, 7—9 and 10—12, all the stems are "deep" stems in the region of the upper skirt. The construction in Figs. 1—3 will not spin in free fall, but will be stable and will resist folding back, and will retard spin imparted by the racket.

35 Referring now to Figs. 4, 5 and 6 a further embodiment of the invention is shown, the basic parts of the shuttlecock have been given similar letters to the previous example but have been raised to the index 1.

40 Referring particularly to Figs. 5 and 6 it will be noticed that the centre line through the depth of the stem (shown here in relation to the diameter $N^1 N^1$) is angled in relation to the diameter $N^1 N^1$ in Fig. 5, and this diameter $N^1 N^1$ passes through the centre of the outside face of the stem and the axis of the shuttlecock. It should be emphasised that this has not been achieved by curving the stems but by inclining their side surfaces a slight angle so that as the air passes from the outside of the shuttlecock to the inside of the shuttlecock it will act on the stem to cause the shuttlecock to spon on its axis. It should be understood that in free fall, or in flight where no spin has been imparted by the racket, the stems will cause spinning to occur. However, in many cases, the racket itself imparts spin when triking the shuttlecock; in such event the stems act to reduce excessive spin or to change the direction of spin. In the example shown in Figs. 4, 5 and 6 a line joining the centre of the outside face of any two opposite stems will pass through the axis of the shuttlecock and the centre of the outer surface of these stems remains on the dia-

meter $N^1 N^1$ throughout the length of the skirt. Referring now to Figs. 7, 8 and 9 the same letters have been given to the same basic parts of the shuttlecock but the index number has been raised to 2. In this example the effect of increasing the angling of the centre line through the depth of the stem in relation to the diameter $N^2 N^2$ is clearly shown.

75 Referring now to Figs. 10, 11 and 12 the same basic parts of the shuttlecock have been given the same letters but raised to the index number 3 and in this example the stems have been laid back in the area of the upper skirt at an angle of less than 90° from the cap in addition to being angled in the manner referred to in Figs. 4, 5, 6, 7, 8 and 9. This also has the effect of promoting spin, or of reducing the spin if the shuttlecock is spinning at greater than the designed speed.

WHAT WE CLAIM IS:—

1. A one piece moulded flared skirt structure for shuttlecocks having an end ring from which stems supporting the vane area extend outwardly, said skirt being composed of an upper skirt and a lower skirt; the lower skirt constituting the vane area and having a length which occupies not less than 30% and not more than 70% of the total length of the skirt, and being made up of stems and thin vane material between those stems; the upper skirt being made up of not less than 7 and not more than 25 stems having large air spaces between them and having their side surfaces directly exposed to air flow through said spaces from the outside to the inside of the shuttlecock; characterised in that the average depth of the stems in the region of the upper skirt is at least twice and not more than eight times the average width of the said stems in the same region.

2. A moulded skirt structure as claimed in any of the preceding claims, in which the centre line through the outer surface of each stem is straight and lies in the surface of the frustum of a right circular cone.

3. A moulded skirt structure as claimed in either of the preceding claims in which the deep stems have flat side surfaces and taper in depth for a maximum at the root end to a minimum at the outer end.

4. A moulded skirt structure as claimed in Claim 5 in which the deep stems taper in width from a maximum at the root end to a minimum at the outer end.

5. A moulded skirt structure as claimed in any of the preceding Claims 2 to 4, in which the projection of the centre line along the outside surface of each stem passes through a common point located on the main axis of the shuttlecock.

6. A moulded skirt structure as claimed in any of the preceding Claims 2 to 4, in which the stems are laid back so that the projection of the centre line along the outside surface of each stem does not pass through any point on the main axis of the shuttlecock but passes through a circle generated from the main axis of the shuttlecock in a plane perpendicular to that axis, to make the shuttlecock spin. 40
7. A moulded skirt structure as claimed in any of the preceding claims in which the centre line through the depth of the deep stems is coincident with a radius generated from the main axis of the shuttlecock in a plane normal to said axis. 45
8. A moulded skirt structure as claimed in any of the preceding Claims 1 to 6, in which the deep stems are angled so that the centre line through their depth is inclined slightly to a radial line passing from the centre of the outside face of the stem to the main axis of the shuttlecock, to make the shuttlecock spin. 50
9. A shuttlecock having a moulded skirt structure as claimed in any of the preceding claims. 55
10. A Badminton shuttlecock having a moulded skirt structure as claimed in any of the preceding Claims 1 to 8. 60
11. A shuttlecock of the type specified comprising a striking cap and a one-piece moulded flared skirt, the said flared skirt being composed of an upper skirt and a lower skirt; the length of the lower skirt occupying not less than 30% and not more than 70% of the total length of the skirt; the upper skirt being made up of between 7 and 25 stems having large air spaces between them and having their side surfaces directly exposed to air flow through said spaces from the outside to the inside of the shuttlecock; and the lower skirt being made up of stems and thin vane material between said stems; the upper skirt structure being characterised in that the average depth of the stems in this region is at least twice and not more than eight times the average width of the said stems in the same region.
12. A moulded skirt structure for shuttlecocks as claimed in Claim 1, substantially as herein described.
13. A shuttlecock substantially as herein described with reference to Figs. 1 to 3 of the accompanying drawings. 55
14. A shuttlecock substantially as herein described with reference to Figs. 4 to 6 of the accompanying drawings.
15. A shuttlecock substantially as herein described with reference to Figs. 7 to 9 of the accompanying drawings. 60
16. A shuttlecock substantially as herein described with reference to Figs. 10 to 12 of the accompanying drawings.

URQUHART-DYKES & LORD,
 Maxwell House, 11 Arundel St.,
 Strand, London, W.C.2,
 and
 12 South Parade,
 Leeds 1, Yorks.,
 Chartered Patent Agents.

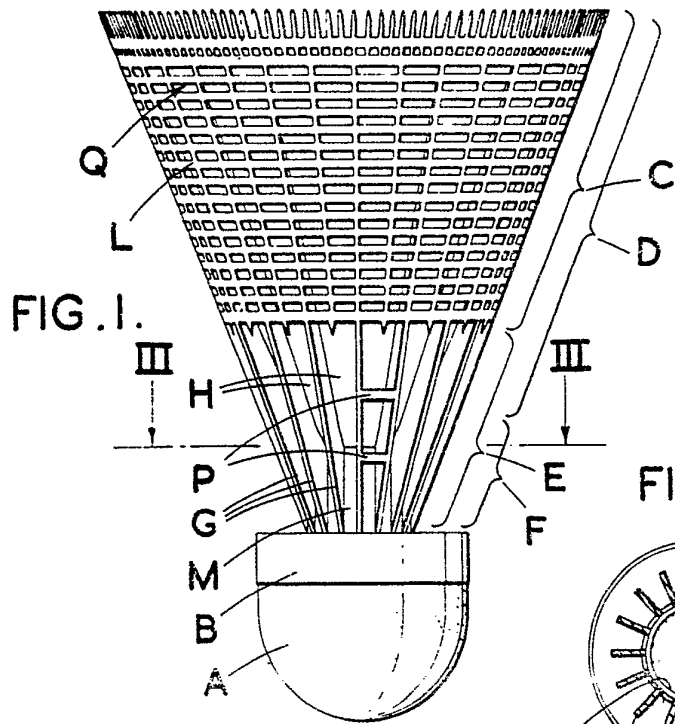

FIG. 3.

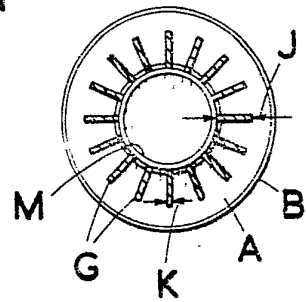

FIG. 2.

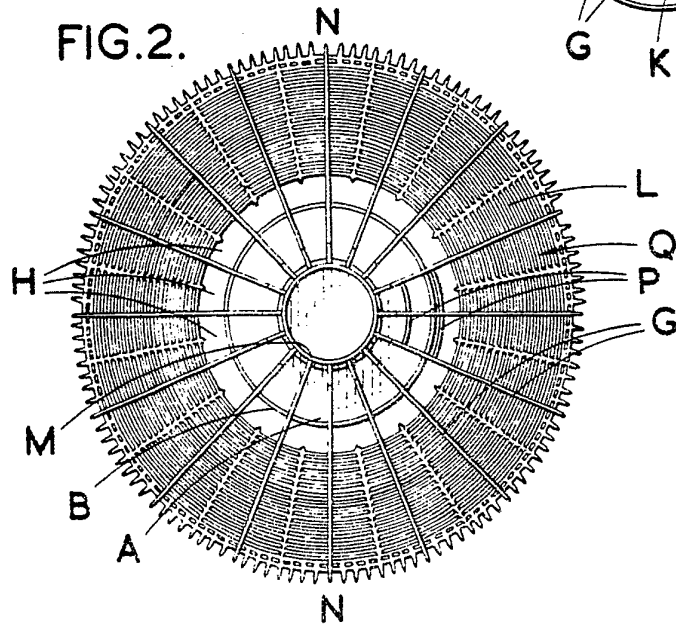

FIG. 4.

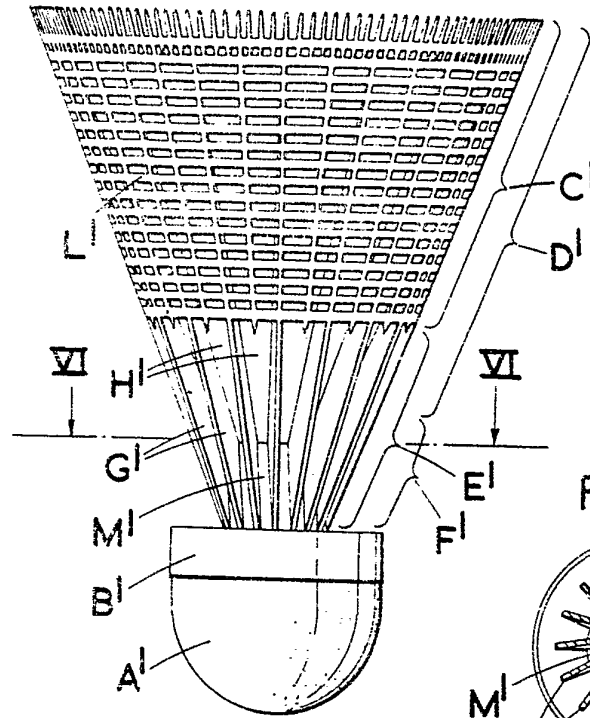

FIG. 6.

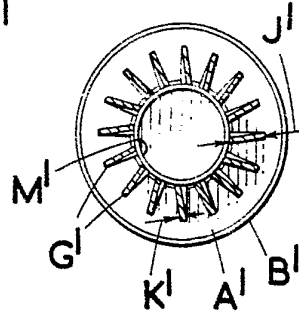
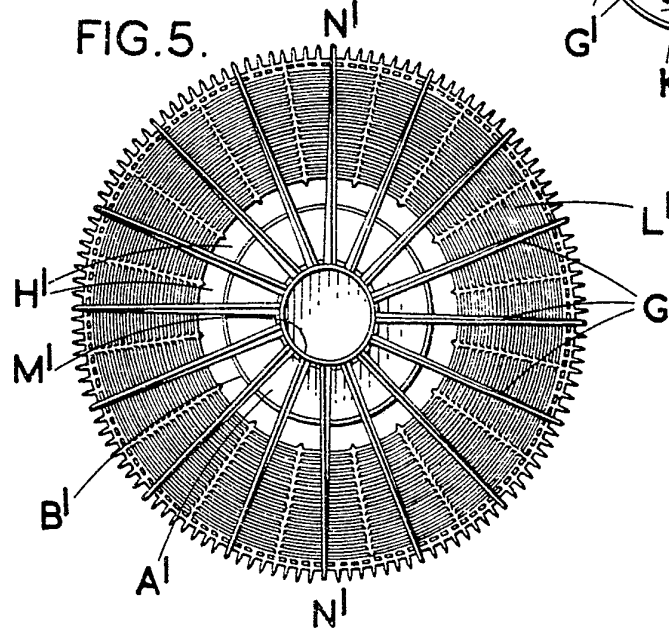
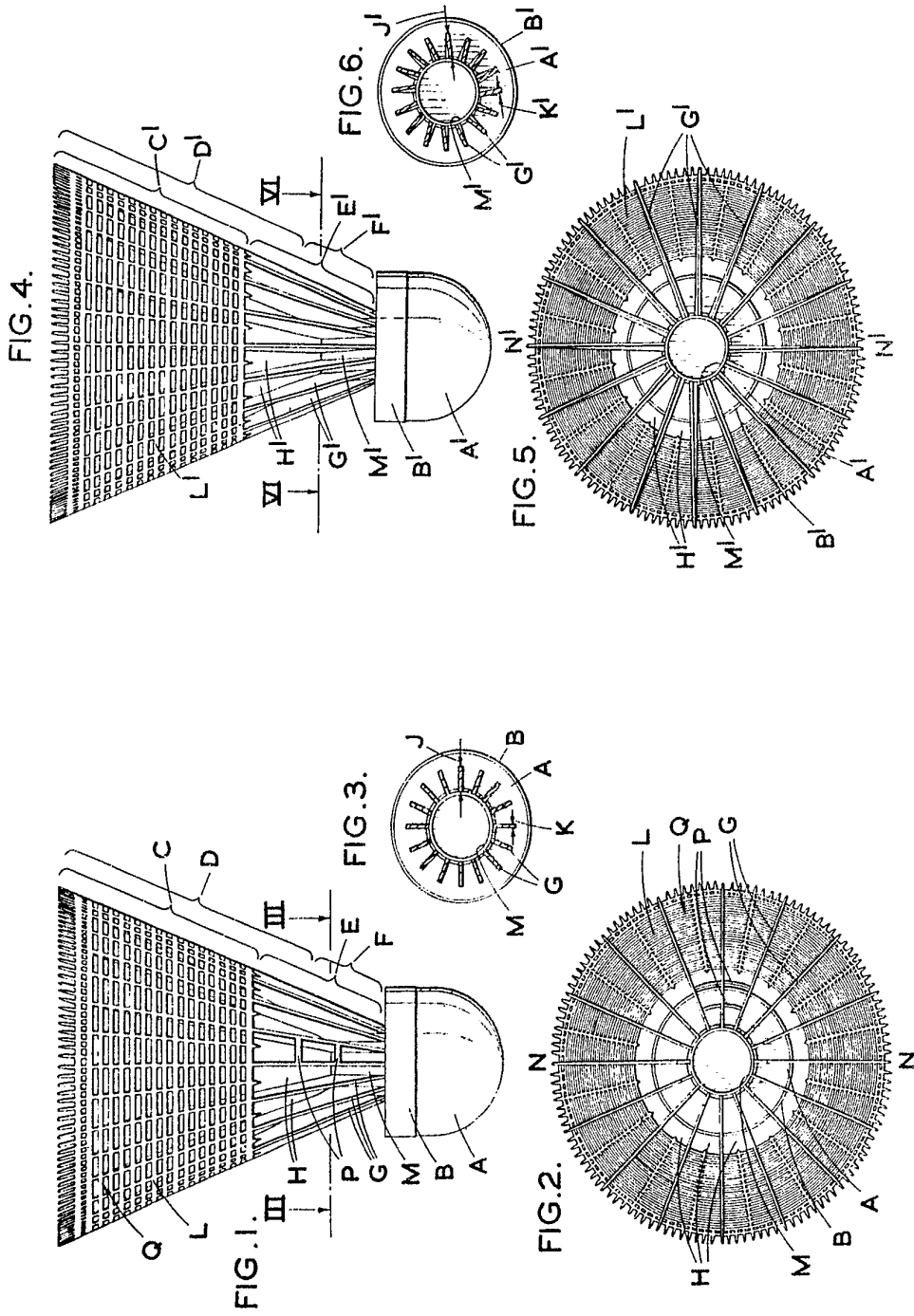
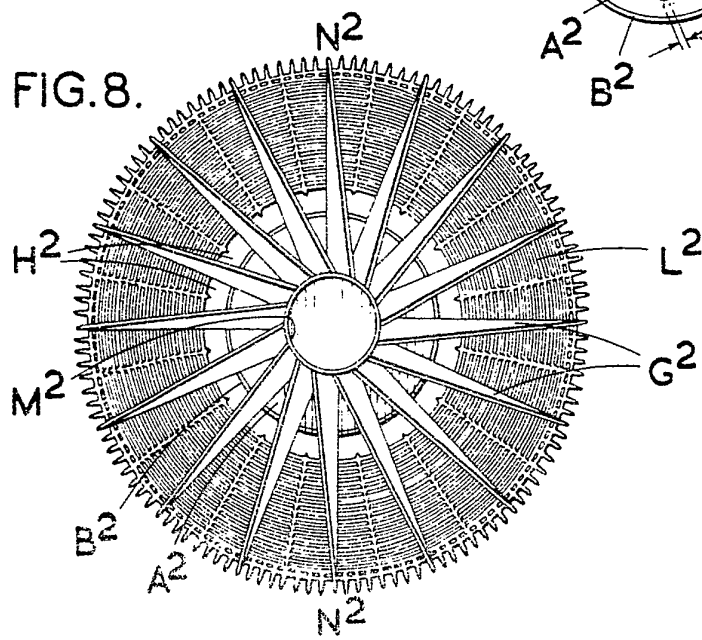
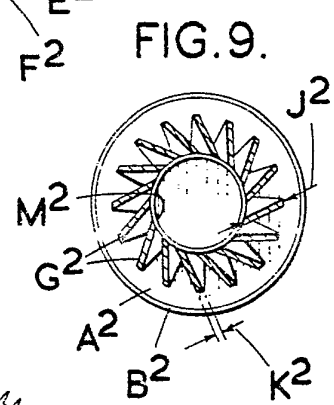
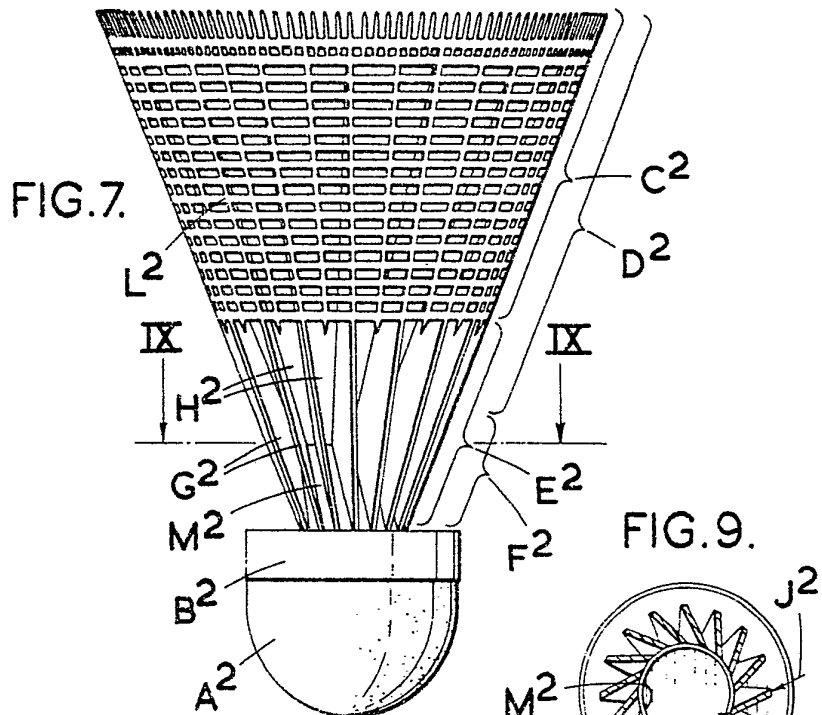
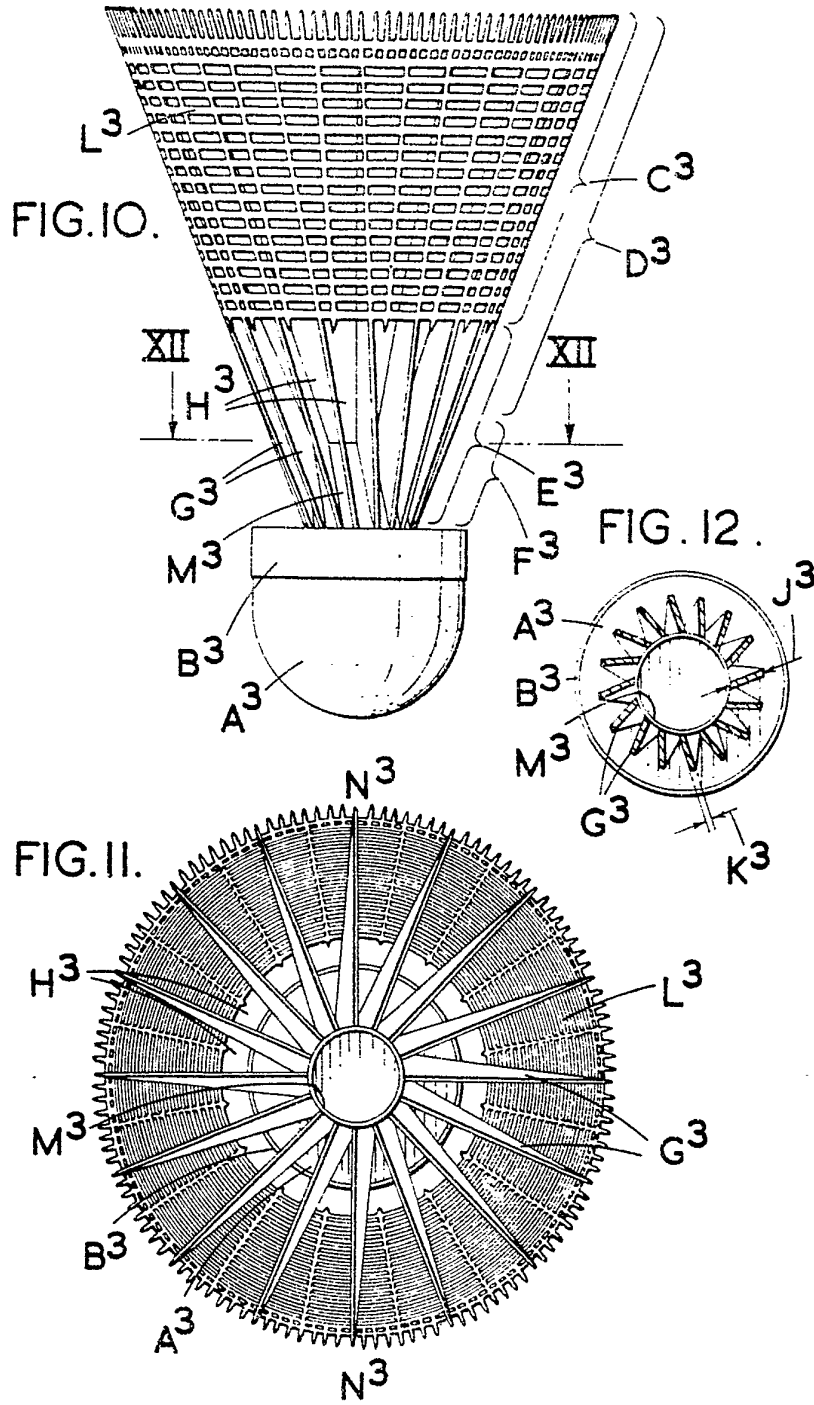

FIG. 5.









2
2

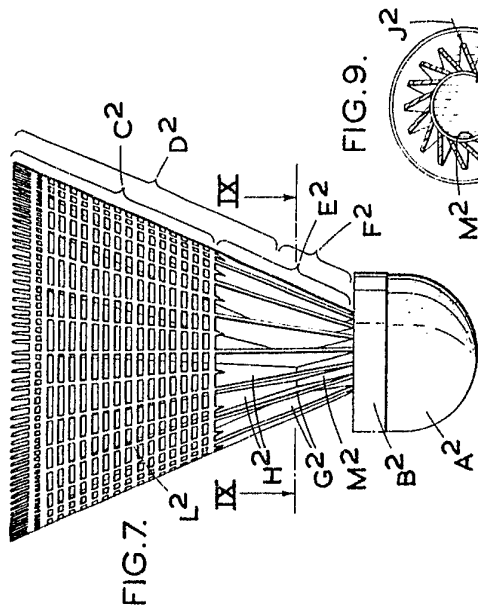

FIG. 7.

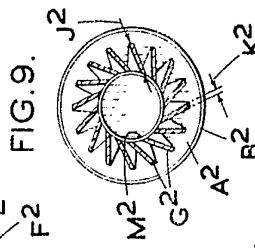

FIG. 9.

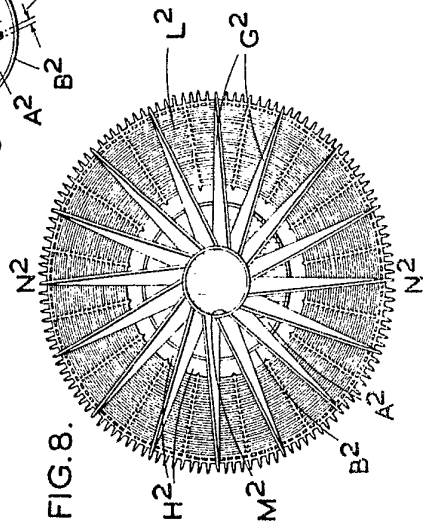

FIG. 8.

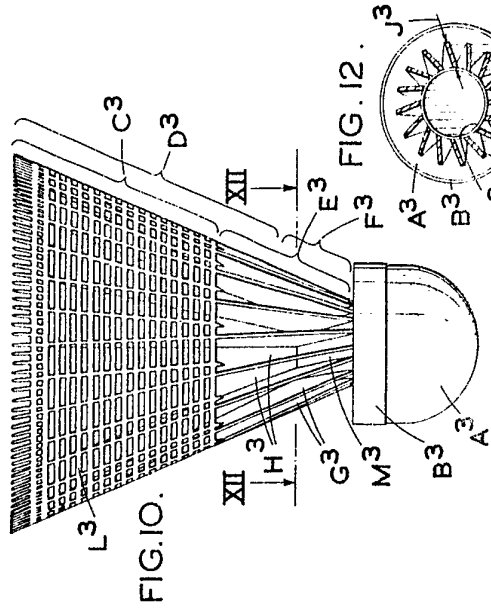

FIG. 10.

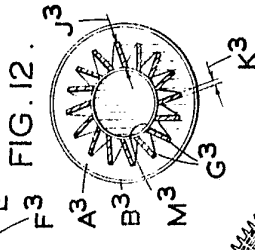

FIG. 12.

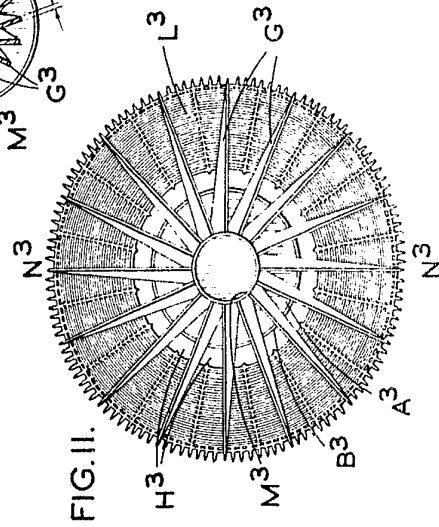

FIG. 11.